

**ASCENT**  
**HYBRID PCP AIR RIFLE**  
**WITH BUILT IN PUMP**

User Instruction Manual





**Air**  
**venturi**  
The Power of Air®

3,625 PSI / 250 BAR Maximum Fill Pressure

## CONTENTS

Rules of safe shooting .....	3
Warnings .....	4
Parts of your Ascent air rifle.....	5
Operating the safety .....	6
Trigger .....	6
Pressurizing with built-in pump.....	7
Pressurizing with compressed air.....	7
Depressurizing the air rifle.....	8
Using a single-shot tray .....	8
Loading the rotary magazine.....	9
Inserting the rotary magazine.....	9
Pump handle lock & release button.....	10
Automatic overpressure relief valve .....	10
Hammer spring adjustment .....	11
Advance trigger adjustment.....	12
Maintenance .....	13
Troubleshooting.....	13
Warranty .....	14

 <b>IMPORTANT</b>	<b>YOU AND OTHERS WITH YOU SHOULD ALWAYS WEAR SAFETY GLASSES TO PROTECT YOUR EYES. READ ALL INSTRUCTIONS BEFORE USING.</b>	
---	--	---

## RULES OF SAFE SHOOTING

- **NEVER** point the airgun at any person.
- **NEVER** point the airgun at anything you do not intend to shoot.
- **ALWAYS** treat the airgun as if it was loaded and handle it with the same respect you would a firearm.
- **ALWAYS** aim in a **SAFE DIRECTION**. **ALWAYS** keep the muzzle pointed in a **SAFE DIRECTION**.
- **NEVER** put any part of your hand over the muzzle.
- **ALWAYS** keep the airgun **ON "SAFE"** until you are ready to shoot in a **SAFE DIRECTION**.
- Check behind and beyond your target to be certain you have a safe backstop and that no person or property can be endangered.
- Place the backstop in a location that will be safe should the backstop fail.
- Replace the backstop if it becomes worn.
- **ALWAYS** be sure of your target and what lies beyond it in case you miss.
- **NEVER** shoot at hard surfaces, water or anything else that may cause a ricochet.
- This airgun may only be used where your local laws permit or at shooting ranges allowed by the law, and only if the ammunition does not travel further than the shooting area. Keep in mind the maximum range of the ammunition. **ALWAYS** abide by laws and regulations that apply to airguns.
- **ALWAYS** check to see if the airgun is **ON "SAFE"** and unloaded when getting it from another person or from storage.
- **ALWAYS** keep your finger off the trigger and away from the trigger guard until ready to shoot.
- You and others with you should **ALWAYS** wear safety shooting glasses to protect your eyes.
- If your reading or prescription glasses are not certified safety glasses, make sure you wear shooting glasses over your regular glasses.
- The shooter and everyone in the vicinity should wear hearing protection when shooting and filling guns with high pressure air.
- **NEVER** load your gun until you're ready to shoot and it's safe to do so.
- **ALWAYS** use the correct caliber ammunition that is suitable for the airgun. Use **ONLY** ammunition designed for this airgun.
- **NEVER** reuse ammunition.
- **ALWAYS** store the airgun with the safety **ON "SAFE"**, unloaded, uncocked, separated from the ammunition, out of the reach of children, and in a secure location to prevent unauthorized people from accessing it.
- **DO NOT** attempt to disassemble or tamper with the airgun.
- **DO NOT** put the airgun away loaded.
- **ALWAYS** store this airgun in a safe location.
- **ALWAYS** store ammunition separately from the gun.
- **NEVER** leave the airgun loaded if it is out of your reach.
- **ALWAYS** unload the airgun before giving it to someone else.
- **ALWAYS** read and follow the manufacturer's manual and instructions.
- **NEVER** let a person who has not completely read this manual use this product.

# ALWAYS FOLLOW THESE SAFETY WARNINGS

**! WARNING:** NOT A TOY. THIS AIR RIFLE IS INTENDED FOR ADULT USE ONLY. MISUSE OR CARELESS USE MAY CAUSE SERIOUS INJURY OR DEATH. MAY BE DANGEROUS UP TO 1,000 YARDS (914 METERS).

**! WARNING:** DO NOT BRANDISH OR DISPLAY THIS AIRGUN IN PUBLIC; IT MAY CONFUSE PEOPLE AND MAY BE A CRIME. POLICE AND OTHERS MAY THINK IT IS A FIREARM. DO NOT CHANGE THE COLORATION OR MARKINGS TO MAKE IT LOOK MORE LIKE A FIREARM. THAT IS DANGEROUS AND MAY BE A CRIME.

**! WARNING:** THIS IS A HIGH POWERED AIRGUN INTENDED FOR USE BY THOSE 18 YEARS OF AGE OR OLDER. READ ALL INSTRUCTIONS BEFORE USING. BUYER AND USER HAVE THE DUTY TO OBEY ALL LAWS ABOUT THE USE AND OWNERSHIP OF THIS AIRGUN.

**! WARNING:** BE SURE THE AIRGUN IS ALWAYS POINTED IN A SAFE DIRECTION. NEVER POINT THE AIRGUN AT ANYONE EVEN IF IT IS UNLOADED. ALWAYS ASSUME AND HANDLE THE AIRGUN AS IF IT WERE LOADED AND READY TO FIRE.

**! WARNING:** THIS PRODUCT CAN EXPOSE YOU TO CHEMICALS INCLUDING LEAD, WHICH IS KNOWN TO THE STATE OF CALIFORNIA TO CAUSE CANCER AND BIRTH DEFECTS OR OTHER REPRODUCTIVE HARM. FOR MORE INFORMATION GO TO [WWW.P65WARNINGS.CA.GOV](http://WWW.P65WARNINGS.CA.GOV).

**! WARNING:** USE ONLY COMPRESSED AIR IN THIS RIFLE. DO NOT USE OTHER GASSES, INCLUDING OXYGEN, WHICH CAN CAUSE A FIRE OR EXPLOSION THAT MAY RESULT IN SERIOUS INJURIES OR DEATH.

**! WARNING:** TREAT YOUR AIR RIFLE AS IF IT IS ALWAYS LOADED AND READY TO FIRE. ALWAYS KEEP THE MUZZLE POINTED IN A SAFE DIRECTION. BE AWARE OF RICOCHET. NEVER SHOOT AT HARD SURFACES OR INTO WATER.

**! WARNING:** DO NOT DISASSEMBLE OR ALTER YOUR AIR RIFLE. REPAIR SHOULD ONLY BE DONE BY AN AUTHORIZED REPAIR DEPARTMENT. OTHERWISE YOU WILL VOID YOUR WARRANTY.

**! WARNING:** THIS AIR GUN IS DESIGNED FOR USE AT PRESSURES BETWEEN 10MPa ~ 25MPa (100BAR ~ 250BAR / 1450PSI ~ 3625PSI). MAX PRESSURE OF INTERNAL AIR RESERVOIR IS 25MPa (250BAR / 3625PSI). DO NOT FILL PAST THE MAX PRESSURE.

**! WARNING:** NEVER COCK THE AIR RIFLE WHEN IT IS NOT IN USE. IT WILL CAUSE ACCELERATED HAMMER SPRING DEGRADATION AND WILL AFFECT THE INITIAL VELOCITY.

# PARTS OF YOUR ASCENT AIR RIFLE

Familiarize yourself with the name of parts to better understand this Operation Manual.

**WARNING:** BE SURE THE AIRGUN IS ALWAYS POINTED IN A SAFE DIRECTION. NEVER POINT THE AIRGUN AT ANYONE EVEN IF IT IS UNLOADED. ALWAYS ASSUME AND HANDLE THE AIRGUN AS IF IT WERE LOADED AND READY TO FIRE.

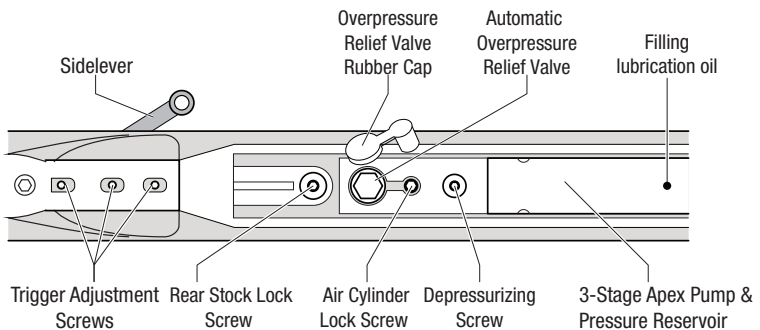
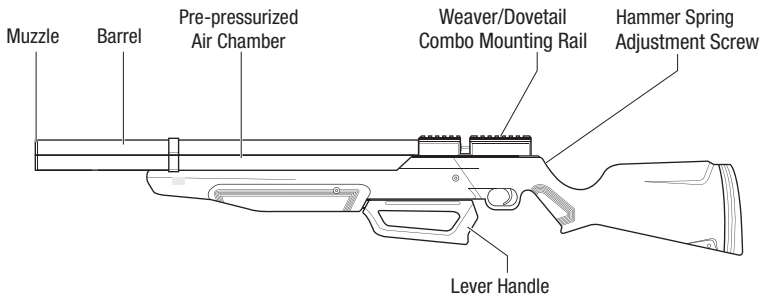
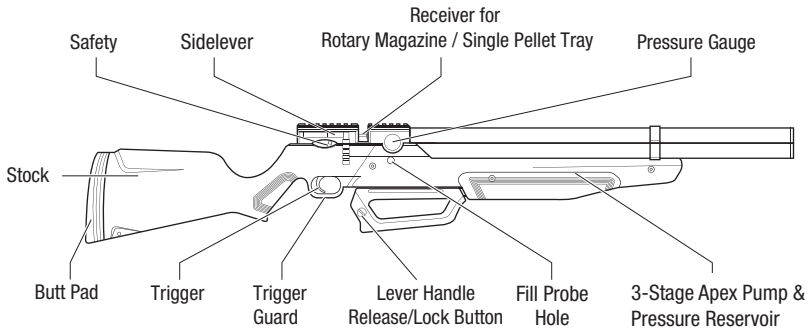

© NOVA VISTA® / [www.nova-vista.co](http://www.nova-vista.co)

## OPERATING THE SAFETY

1) The safety is located above the trigger. It allows you to set this air rifle to “S” (SAFE) and “F” (FIRE) positions.

2) Setting “S” (SAFE) Position: Pull rearward and the safety should point to the “S” indicator, and at the same time the safety should cover the red dot. (Fig. 2a)

3) Setting “F” (FIRE) Position: Push forward and the safety should point to the “F” indicator, and at the same time show the red dot signifying it is ready for shooting. (Fig. 2b)

4) The safety is only allowed to point at “S” or “F” position. Do not position in the middle of “S” and “F”. (Fig. 2c)

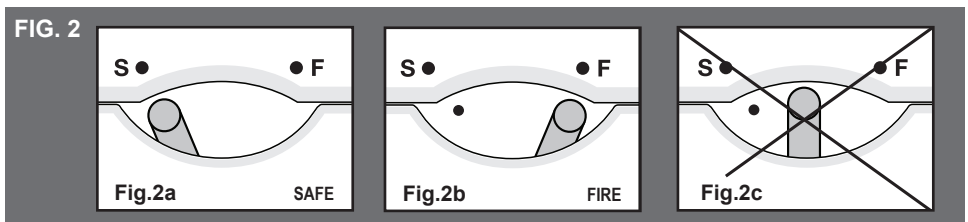

**⚠ WARNING:** ALWAYS MANUALLY AND VISUALLY KEEP AIR RIFLE IN THE “S”(SAFE) POSITION UNTIL YOU ARE ACTUALLY READY TO SHOOT. FAILURE TO FOLLOW THESE INSTRUCTIONS MAY RESULT IN SERIOUS INJURIES OR DEATH.

**⚠ WARNING:** LIKE ALL MECHANICAL DEVICES, AN AIR RIFLE SAFETY CAN FAIL. EVEN WHEN THE SAFETY IS SET TO “S” (SAFE) POSITION, CONTINUE HANDLING THE AIR RIFLE SAFELY. NEVER POINT THE AIR RIFLE AT ANY PERSON AND ANYTHING YOU DO NOT INTEND TO SHOOT.

## TRIGGER

1) This trigger can be adjusted according to individual preference. It has been factory set to an efficient setting that will suit most hunting and target uses. It should not need to be modified. If you are experienced in making such adjustments, please read the Advanced Trigger Adjustment section.

2) Keep your trigger finger out of the trigger guard until you have decided to shoot.

## PRESSURIZING (FILLING) WITH BUILT IN APEX PUMP

- 1) Release the pump handle lock button and hold the pump handle. (Fig. 3)
- 2) Extract the lever handle to the maximum angle position.
- 3) Push it back to its original position, which will complete the pump cycle.
- 4) Repeat this until you have achieved the desired pressure in this air rifle.
- 5) Observe the pressure on the pressure gauge. Do not pump beyond 3,625 PSI (250 BAR).

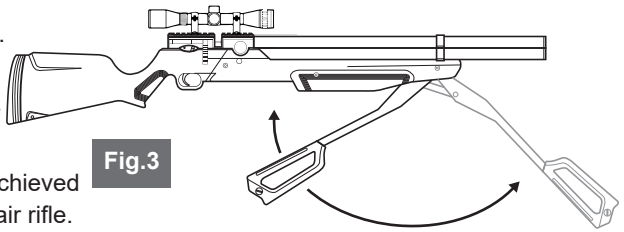

## PRESSURIZING (FILLING) WITH COMPRESSED AIR

- 1) Locate the fill probe hole (Fig. 4a).
- 2) If present, remove the rubber cap on the fill probe hole (Fig. 4b).
- 3) Insert the fill probe into the fill probe hole (Fig. 4c).
- 4) Connect your fill source and fill the rifle no greater than the maximum fill pressure of 3,625 PSI (250 BAR).
- 5) When you've reached the desired pressure, depressurize the hose on your fill source and remove the fill probe before using the rifle.

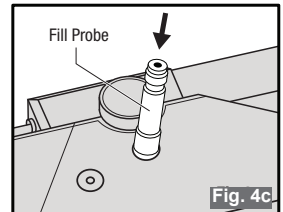
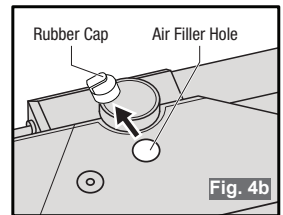

<b>⚠ DANGER:</b>	
	<b>DANGER OF EXPLOSION!</b> Overfilled compressed air cylinder Do NOT exceed maximum fill pressure of your cylinder at room temperature!

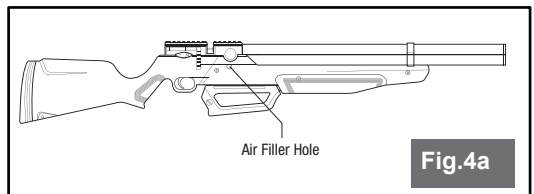

<b>⚠ WARNING:</b>	THE AIR SHOULD BE PRESSURIZED SLOWLY. OTHERWISE, HEAT IS GENERATED THAT AFFECTS THE ACCURACY OF THE PRESSURE. OVERPRESSURE CAN CAUSE EXPLOSIONS, SERIOUS INJURIES OR DEATH.
-------------------	---

<b>⚠ WARNING:</b>	THIS AIR GUN DESIGNED FOR USE AT PRESSURES BETWEEN 10MPa ~ 25MPa (100BAR ~ 250BAR / 1450PSI ~ 3625PSI).
-------------------	---

## DEPRESSURIZING THE AIR RIFLE

- 1) Extract the pump handle to the maximum angle position and locate the depressurizing screw.
- 2) Using the Allen wrench (provided in the packaging) slowly turn the screw counter-clockwise, do not rotate more than 2 revolutions. (Fig. 5)
- 3) After depressurizing the air, use the Allen wrench to tighten the screw clockwise.
- 4) Check the pressure gauge to make certain all pressure has been removed from this air rifle.

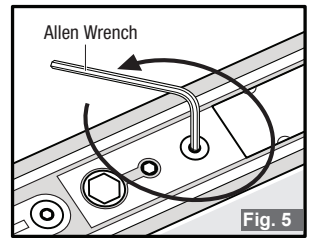

**⚠ WARNING:** PERFORMING THE ABOVE PROCEDURE MAY EXHAUST AIR FROM THE BARREL AT A HIGH RATE AND COULD DISCHARGE A PELLET THAT IS CHAMBERED. ALWAYS MAKE CERTAIN THIS AIR RIFLE IS POINTED AT A SAFE DIRECTION.

## THE USE OF SINGLE PELLET TRAY

- Make sure the Safety is on "S" (SAFE) position and keep the muzzle pointed in a safe direction.
- Pull the bolt back to the cocked position.
- Insert the single pellet tray into the receiver. (Fig. 6a)
- Push and pull the bolt and make sure the receiver locking pin moves forward and backward freely.
- Lay a pellet of appropriate caliber in the pellet tray. (Fig. 6b)
- Push the bolt forward as far as possible. This chambers a pellet into the barrel and this air rifle is ready to fire. Be careful not to squeeze or damage the pellet as this could affect accuracy.

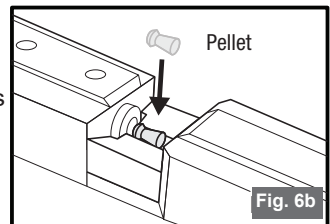
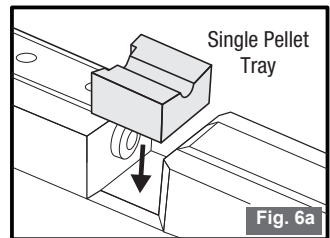

**⚠ IMPORTANT** ONLY ALLOW ONE PELLET EACH TIME. DO NOT LOAD MORE THAN ONE PELLET INTO THE CHAMBER, OTHERWISE IT MAY CAUSE DAMAGE AND MAY NOT FIRE.

## LOADING THE ROTARY MAGAZINE

- Lift the transparent cover and turn clockwise along the direction of the arrow until it stops. (Fig. 7a, Fig. 7b)
- Place a finger under the magazine covering the hole.
- Place the first pellet in the magazine head first. Make certain the pellet does not protrude out the back of the magazine. In the event the pellet does protrude simply push the pellet inward. Be careful not to squeeze or damage the pellet as this could affect accuracy. (Fig. 7c)
- Rotate the cover counter-clockwise and place the remaining pellets into the magazine. Once full, lock the cover at the starting position and the magazine is now ready for use. (Fig. 7d)

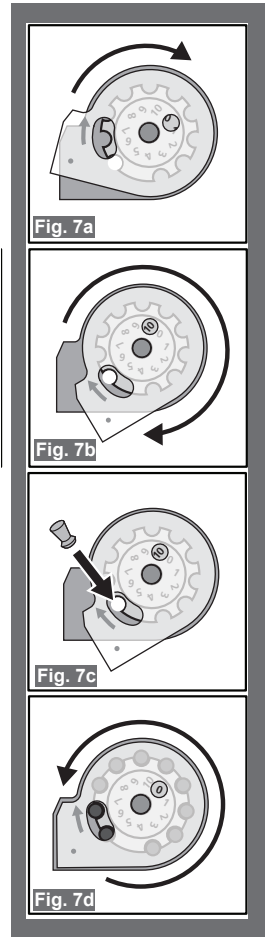

## INSERTING THE ROTARY MAGAZINE

- 1) Make sure the Safety is on "S" (SAFE) position and keep the muzzle pointed in a safe direction.
- 2) Pull the bolt back to the cocked position.
- 3) With the transparent cover of the magazine facing to the back of the air rifle, insert the magazine from the right side and push it left until it snaps into place. (Fig. 8a)
- 4) Push the bolt forward until it stops, to chamber a pellet.
- 5) This air rifle is now ready to fire.
- 6) Only one pellet should be pushed into chamber each time.
- 7) Do not repeat until you have fired the loaded pellet, this prevents more than one pellet feeding into the chamber.
- 8) This magazine is designed to stop automatically when empty. Pull the bolt, and push the magazine out of the receiver from the left side. (Fig. 8b)
- 9) Repeat the steps if you wish to continue shooting.

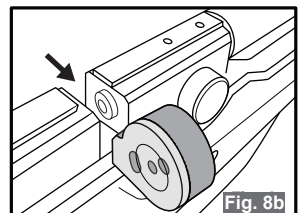
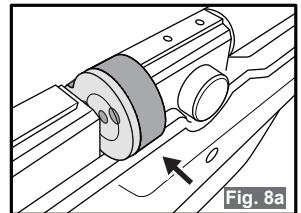

## PUMP HANDLE LOCK AND RELEASE BUTTON

- 1) Locate the pump handle lock and release button near the trigger on both sides of this air rifle.
- 2) Refer to Fig. 10a, press the button to lock the pump handle.
- 3) Refer to Fig. 10b, press the button to release the pump handle

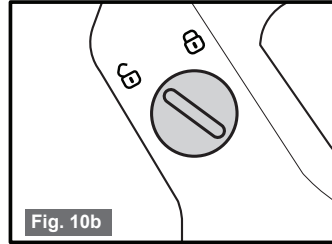
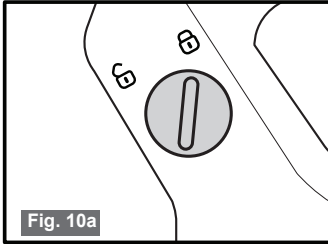

## AUTOMATIC OVERPRESSURE RELIEF VALVE

- 1) This air rifle is equipped with an automatic overpressure relief valve (Fig. 11). It protects the other parts of the air rifle from damage.
- 2) If damaged or it loses function, please contact Air Venturi for replacement at: **216-220-1180**.

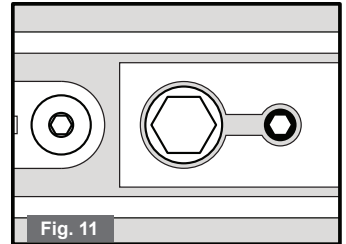

## HAMMER SPRING (VELOCITY) ADJUSTMENT

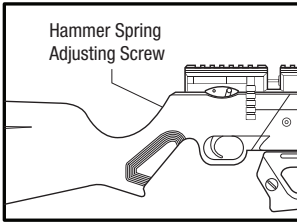
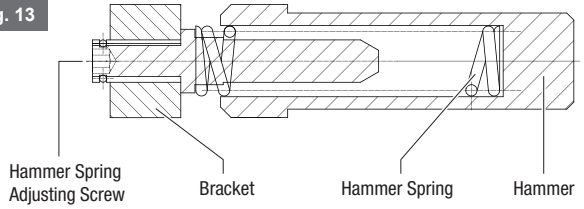

Fig. 13



- 1) Image (Fig. 13) explains where the hammer spring adjusting screw is located.
- 2) Use the Allen wrench provided to tune the Hammer Spring Adjusting Screw.
- 3) To increase velocity and tension of the hammer spring, rotate the Hammer Spring Adjusting Screw clockwise. To decrease velocity and hammer spring tension, rotate the Hammer Spring Adjusting Screw counter-clockwise.
- 4) After approximately 3000 shots, the hammer spring adjustment screw may need to be turned clockwise one full turn to maintain factory velocity.

## ADVANCED TRIGGER ADJUSTMENT

**⚠ IMPORTANT** THIS AIR RIFLE IS FOR ADULTS. THE TRIGGER HAS BEEN FACTORY SET TO A SETTING THAT WILL SUIT MOST HUNTING AND TARGET USES. THEREFORE, ADVANCE CALIBRATION IS NOT REQUIRED.

**⚠ WARNING:** ADJUSTMENT OF THE TRIGGER SCREWS COULD INHIBIT PROPER FUNCTION OF THE SAFETY. IT MAY CAUSE THE SAFETY TO NOT POINT AT "S" OR "F" POSITION. ALWAYS CHECK FOR FULL ENGAGEMENT AND SMOOTH FUNCTION OF THE SAFETY UPON COMPLETION OF ANY CHANGES TO THE ADJUSTMENT SCREWS.

**⚠ WARNING:** ADJUSTMENT TO THE TRIGGER ASSEMBLY COULD ALLOW THIS AIR RIFLE TO FIRE IF DROPPED OR JARRED EVEN WITH OR WITHOUT THE SAFETY ENGAGED. THIS CAN CAUSE SERIOUS INJURIES OR DEATH.

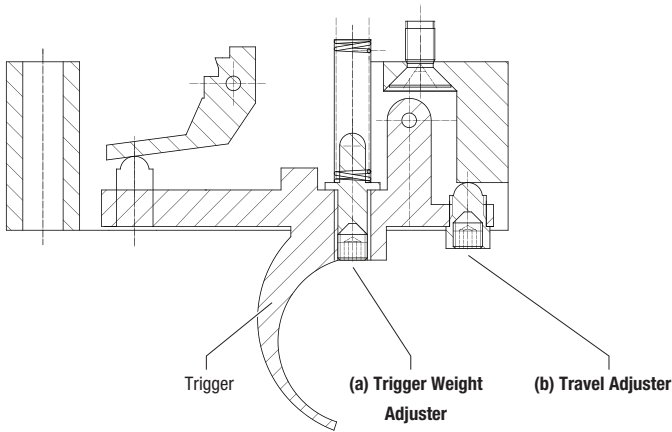

- 1) Make sure the Safety is on "S" (SAFE) position and keep the muzzle pointed in a safe direction.
- 2) Make sure the bolt is push forward and NOT in the cocked position.
- 3) Use Allen wrench provided in the packaging.
- 4) **Trigger Weight Adjuster:** Use the Allen wrench and turn the adjuster screw clockwise to increase trigger pull weight and counter-clockwise to decrease trigger pull weight.
- 5) **Travel Adjuster:** Use the Allen wrench and turn the adjuster screw clockwise to reduce the amount of travel, this will move the trigger back. Turning counter-clockwise will increase the amount of travel and move the trigger forward.

## MAINTENANCE

- 1) Apply a small amount of silicone lubricant to the pellet probe o-rings and barrel o-rings (on either side of the transfer port hole) every 400 shots.
- 2) Apply 5 drops of lubricant oil to the Apex Pump every 400 shots. Locate the lubrication hole after lifting the pump arm and extending it fully.

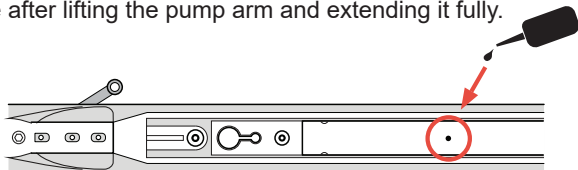

- 3) Keep this air rifle clean and wipe with a cloth occasionally.
- 4) For long term storage, store with pressure between 870 PSI ~ 1160 PSI (60 - 80 BAR) in the air rifle. Store in a place that is dark. Keep the rifle out of high humidity environments for storage.

**⚠ WARNING:** DO NOT INTRODUCE PETROLEUM-BASED LUBRICANTS INTO THE HIGH-PRESSURED RESERVOIR, IT MAY CAUSE AN EXPLOSION. FAILURE TO FOLLOW THESE INSTRUCTIONS MAY RESULT IN SERIOUS INJURIES OR DEATH.

**⚠ WARNING:** REPAIRS SHOULD BE PERFORMED BY A PROFESSIONAL AIRGUN-SMITH AT AN AIR VENTURI SERVICE CENTER. DO NOT ATTEMPT TO DISASSEMBLE OR REPAIR THIS AIR RIFLE WHILE IT IS FILLED WITH AIR PRESSURE. PARTS CAN FLY FROM THIS AIR RIFLE AT DANGEROUS SPEEDS AND MAY CAUSE SERIOUS INJURIES OR DEATH.

## TROUBLE SHOOTING

PROBLEM	PROBABLE CAUSE	SOLUTION
Precision	Pellets	Try different pellets
	Magazine	Check magazine for malfunction, replace if needed
	Barrel breech o-ring	Check breech o-rings for wear or damage, replace if needed.
Trigger won't engage	Adjustment issue or excessive wear	Try adjusting, replace if needed
Air rifle won't fire	Low pressure	Contact you dealer, professional repair may be needed
	Empty of air	Charge the air rifle
	Jammed pellets	Remove jammed pellets from barrel
Safety won't work	Worn parts or improper trigger adjustment	Try adjusting, replace if needed
Built-in pump can't be pumped (pump jammed)	Small piston O-ring	Take out the small piston and replace the O ring.

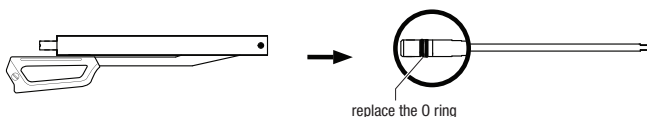

# WARRANTY

## One-Year Limited Warranty

This product is warranted to the retail consumer for one year from date of retail purchase against defects in material and workmanship. In the unlikely event there are any defects in materials or workmanship in the first twelve (12) months after retail purchase, we will repair or replace the defective items under warranty.

### What is covered:

Replacement parts and labor. Transportation charges to consumer for repaired product.

### What is NOT covered:

- Transportation charges to Air Venturi for defective products.
- Any damage or faults caused by owner misuse, action or inaction.
- Damages caused by abuse or failure to perform normal maintenance.
- Any other expense.
- Parts subject to normal wear and tear.
- Consequential damages, incidental damages or incidental expenses including damage to property.

This warranty is in addition to your statutory rights. Retain your sales receipt as proof of purchase.

**NOTE:** *Some states do not allow the exclusion or limitation of incidental or consequential damages, so the above limitation or exclusion may not apply to you.*

### Warranty claims:

Call Air Venturi at **216-220-1180** before returning any product.

### Implied warranties:

Any implied warranties, including the implied warranties of merchantability and fitness for a particular purpose, are limited in duration to one year from date of retail purchase.

**NOTE:** *Some states do not allow limitations on how long an implied warranty lasts, so the above limitation may not apply to you.*

To the extent any provision of this warranty is prohibited by federal, state or municipal law which cannot be preempted, it shall not be applicable. This warranty gives you specific legal rights, and you may also have other rights which vary from state to state and country to country. Illustrations and photographs are for information purposes only and may not show the exact model purchased.

### The warranty shall be invalid if the Airgun:

- Has been incorrectly disassembled, reassembled or maintained.
- Has been fitted with non-Air Venturi parts.
- Has been abused, misused or improperly stored.
- Original purchase receipt cannot be presented.





**AIR VENTURI®**

5135 Naiman Parkway, Cleveland, OH 44139

Ph: 216-292-2570 • fax: 216-373-0086